

◆ Description

SK020G

DAC voice

output with high quality speech , There are 20 second Voice Length under 6 KHz sampling and 4 bit hardware compression. Its internal built-in a oscillator for system clock **without an external resistor**. Maximum 63 voice groups. One Group contain several steps(voice section); **Maximum 700 steps** for all the Groups. **Each Step** can be define **Trigger Mode, Output Status, Voice Section, Mute length, I/O Type** & **Simple Programming Function**. User can select **8bit / 5bit / 4bit** data compression. **Support three mode trigger IC** (Stand Alone, Serial Trigger Mode, CPU Command Mode). Easy use development system is for function selection and voice combination . PC download the ROM code by the USB Port .

◆ Functions

- MAX voice file : 700
- MAX Trigger Groups : 63
- Power On Trigger Group :1
- MAX Step : 700
- Signal step mute length : 0.64 s (6k sample rate)
- Operating Voltage range: 2.4V ~ 3.6V
- Total Voice Duration : 20" (120K Samples)
- I/O pin : 4
- Voice output : PWM or DAC
- Sequential Key : TG1 -> 32 Groups.
TG2 -> 29 Groups.
TG3,TG4-> 1 Group
- Debounce time : 50 us or 10 ms
- On/Off function : only for all TG PIN
- Sequential Key for Volume control function.
- Step can change Trigger I/O Type, Trigger Mode & Output Status.
- Hardware Trigger Group Repeat function.
- **Simple Programming Function :**
 - (a) Write data to working register.
 - (b) Working Register Increasing.
 - (c) Step Jump by Working Register / Volume Status.

- **Three Mode Trigger IC :**

- Key Stand-alone Trigger Mode :

- A. Edge/Level
- B. Hold/Unhold
- C. Retrigger/Irretrigger

- Serial Trigger Mode :

Combinations of TG1 and TG2 to trigger maximum 63 Voice Group.

- CPU Command Mode :

User command through TG1,TG2,TG3 & TG4 with serial CPU Interface to control the Multi-Playback function.

- **Output status** (for each Output pin):

- A. Stand by Status. (High/Low Status)
- B. Busy Low Active.
- C. Busy High Active.
- D. LED Flash at 6 Hz.
- E. LED Flash at 3 Hz.
- F. LED Flash at 1.5 Hz.
- G. LED Flash at 0.75 Hz.

H. PWM for LED Dimming Control.

- **Play rate level :**

Sk020g can provide different play rate in one code as follow below
Reference Sample Rate.

3K, 3.2K, 3.31K, 3.42K, 3.55K, 3.69K, 3.84K, 4K, 4.17K, 4.36K, 4.57K,
4.8K, 5.05K, 5.33K, 5.64K, 6K, 6.4K, 6.85K, 7.38K, 8K, 8.72K, 9.6K,
10.66K, 12K, 13.71K, 16K, 19.2K, 24K.

- **TG2 Low Reset**

- **TG3 Volume Control**

◆ SK020G Pad Location

CHIP SIZE: (0, 0) (1734,715) UM



NO.	PAD NAME	X	Y	NO.	PAD NAME	X	Y
1	TG2/RSTB	-777	-184	6	VSS	440	-266
2	TG1	-777	-270	7	PWM1	793	-288
3	TG3	-605	-267	8	VDD	796	-204
4	TG4	-520	-267	9	PWM2/DAC	793	-119
5	VSS	256	-271				

◆ PIN Descriptions

PIN NAME	I/O	Function
TG1	INPUT	Key Stand-alone Trigger Mode : TG1 is used to trigger the maximum 32 Voice Group one by one sequentially.
		Serial Trigger Mode : TG1 is used to trigger the maximum 63 Voice Group.
		CPU Command Mode : TG1 is used as Data Input Pin (CS).
	OUTPUT	As Output PIN , Output the BUSY or Flash Signal ./By Code Control
TG2/RSTB	INPUT	Key Stand-alone Trigger Mode : TG2 is used to trigger the maximum 21 Voice Group one by one sequentially.
		Serial Trigger Mode : TG2 is used to trigger the maximum 29 Voice Group
		CPU Command Mode : TG2 is used as Clock Pin (CLK).
TG3	INPUT	Key Stand-alone Trigger Mode : TG11 is used trigger Only One Group. CPU Command Mode : TG11 is used as Data Input Pin (DIO1).
	OUTPUT	As Output PIN , Output the BUSY or Flash Signal ./By Code Control
TG4	INPUT	Key Stand-alone Trigger Mode : TG4 is used trigger Only One Group. CPU Command Mode . TG4 is used as Selected Pin (DIO2).
	OUTPUT	As Output PIN , Output the BUSY or Flash Signal./By Code Control
PWM1	OUTPUT	As a PWM PIN , can Directly drive the Speaker .
PWM2	OUTPUT	As a PWM PIN , can Directly drive the Speaker .
		As a DAC PIN , 8 bit D/A Current Output.
VDD	INPUT	Power Supply PIN , @ 2.4~3.6 V Working Voltage.
VSS	INPUT	Connected to Ground.

◆ **TG2 Low Reset**

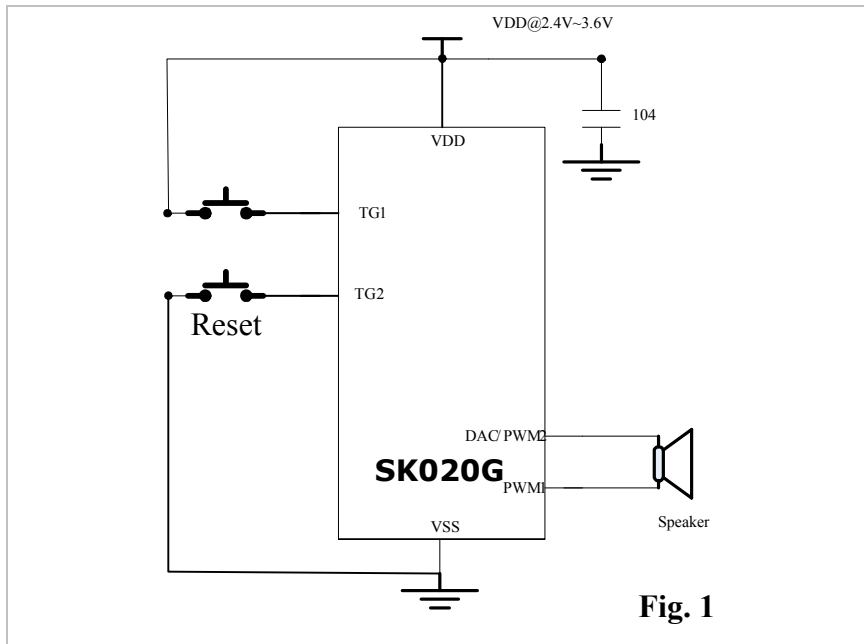

◆ **SK020G Application Circuit**

SK020G 3V Stand-alone Mode

PWM

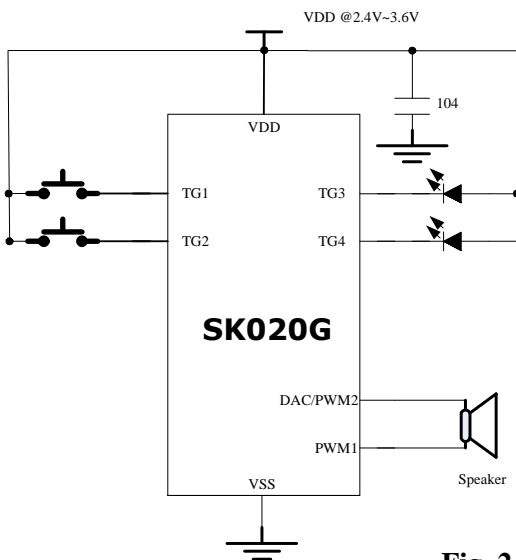

DAC

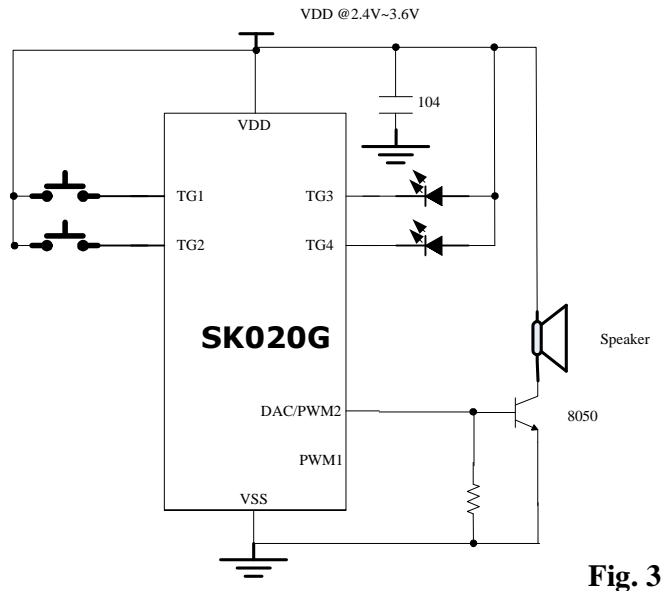

SK020G 3V Serial Mode

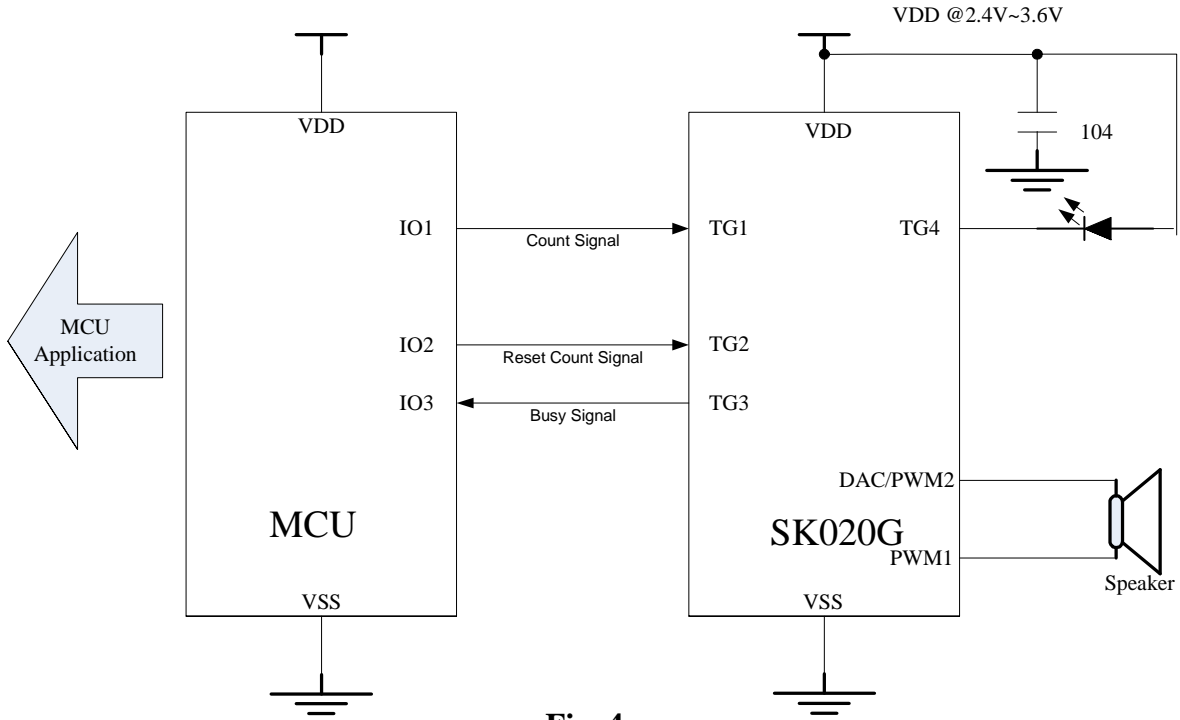

Fig. 4

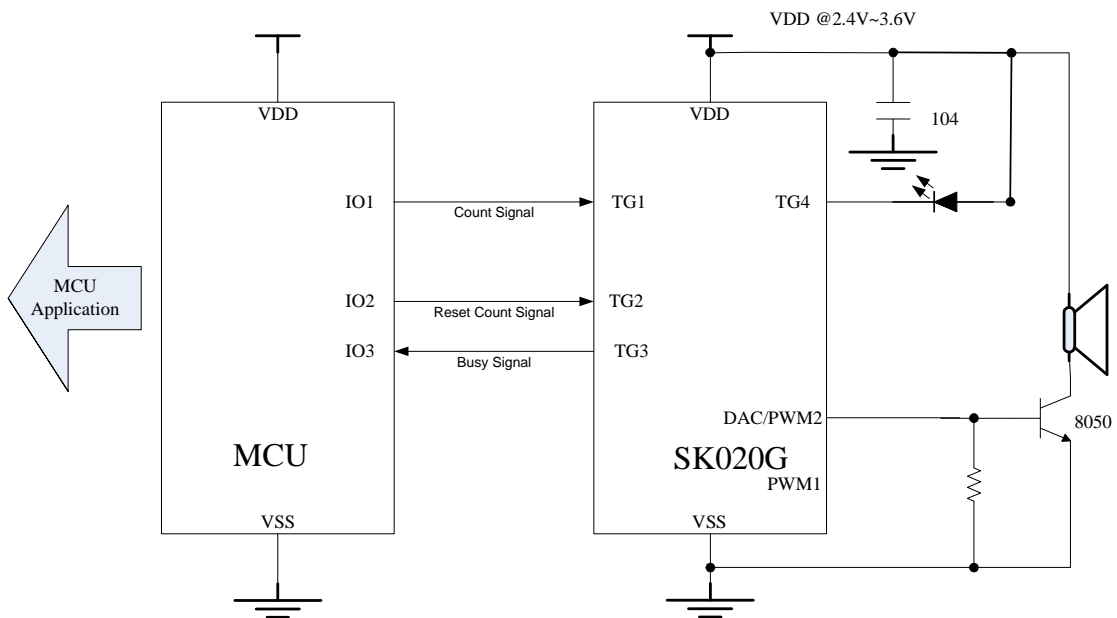

Fig. 5

SK020G 3V CPU Mode

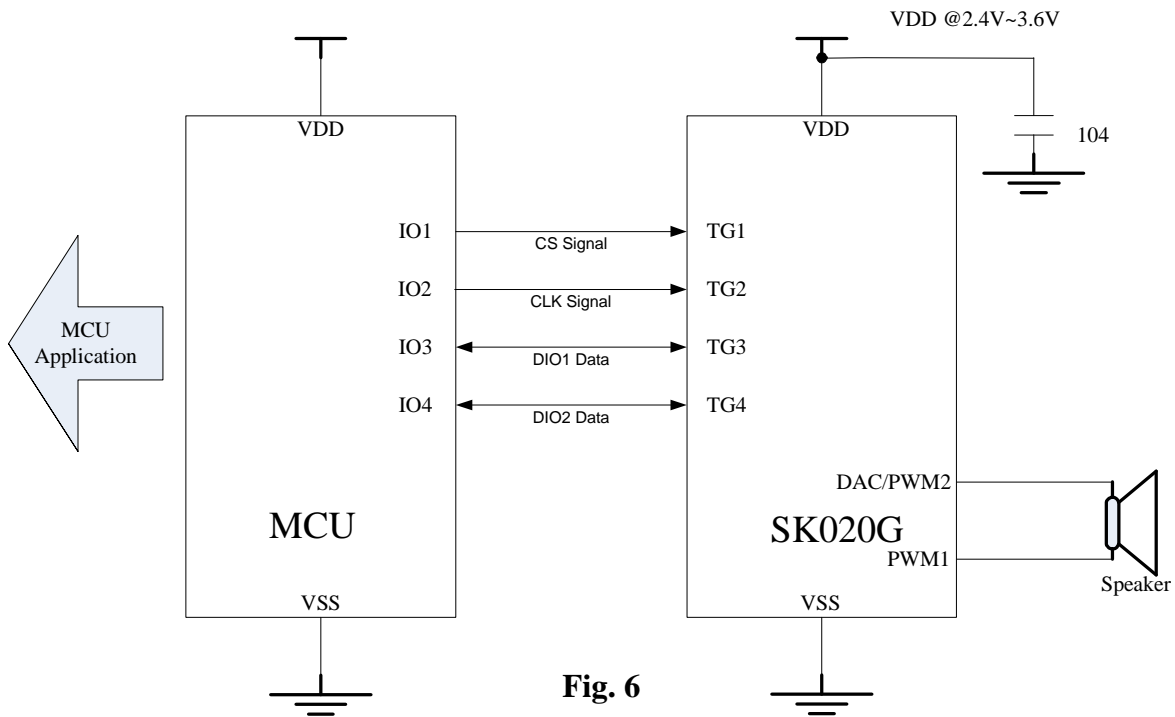

Fig. 6

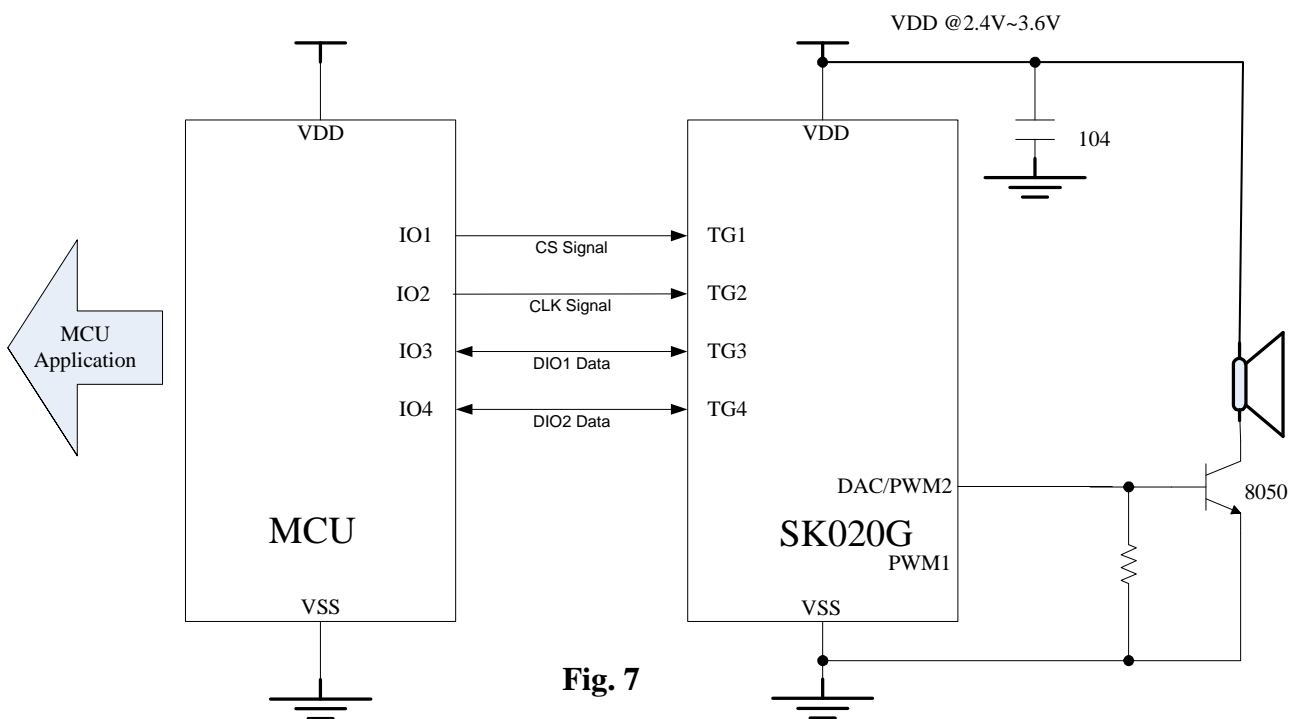
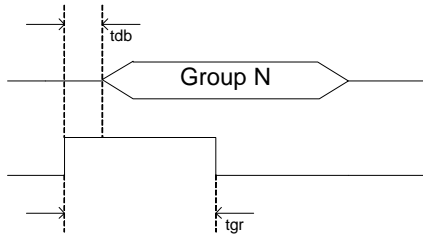

Fig. 7

◆ SK020G Trigger Timing

(a) Trigger Pulse Width < Group Length
Option Setting = Edge / Unhold



(b) Trigger Pulse Width < Group Length
Option Setting = Edge / Hold

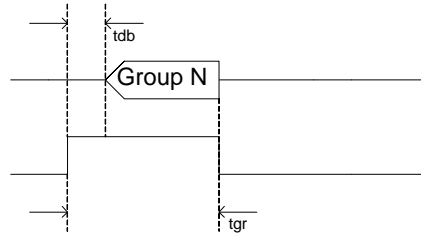

(c) Trigger Pulse Width < Group Length
Option Setting = Level / Unhold

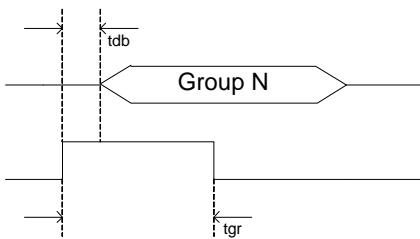

(d) Trigger Pulse Width < Group Length
Option Setting = Level / Hold

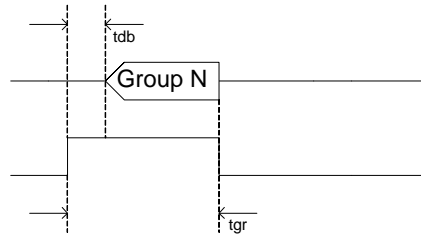

(e) Trigger Pulse Width > Group Length
Option Setting = Edge / Unhold

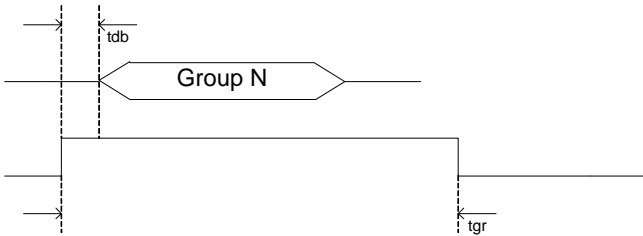

(f) Trigger Pulse Width > Group Length
Option Setting = Edge / Hold

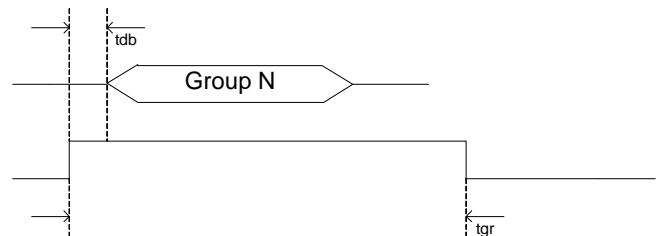

(g) Trigger Pulse Width > Group Length
Option Setting = Level / Unhold

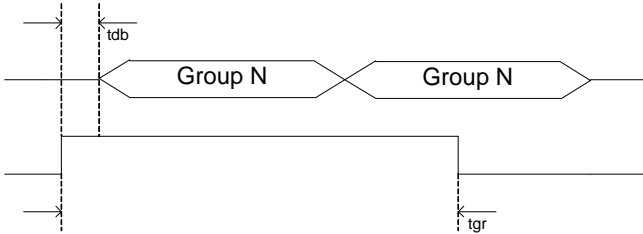

(h) Trigger Pulse Width > Group Length
Option Setting = Level / Hold

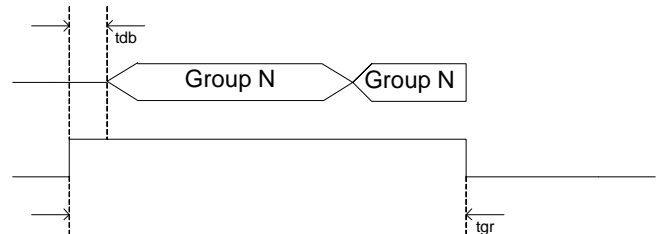

(i) Option Setting = Retrigger

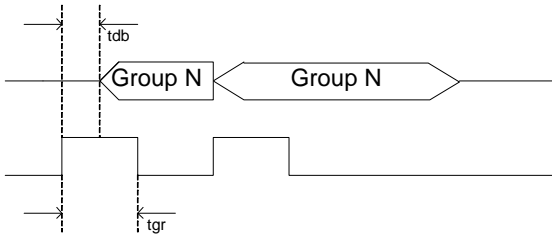

(j) Option Setting = Irretrigger

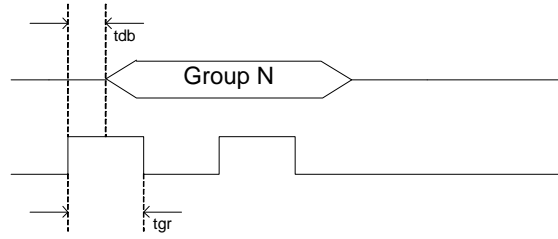

(k) TG1 = Sequential Trigger & From Group1~Group5

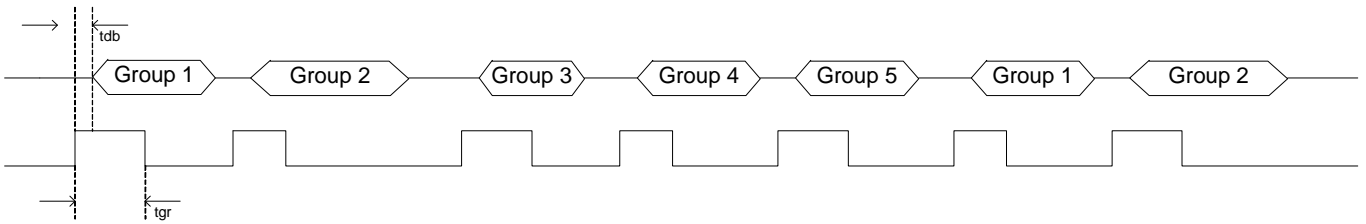

◆ SK020G Trigger Voice Combination Example

Voice File	Description
Voice File A	Hello (1.5'')
Voice File B	Good Morning (3'')
Voice File C	John (1'')
Voice File D	Tom (1'')
Voice File E	Mary (1.5'')

Group1 = Step1 + Step 2

Group 2 = Step3 + Step 4 + Step 5

Group 3 = Step 6 + Step 7

Group1 = Hello John

Group 2= Hello Tom Good Morning

Group 3 = Good Morning Mary

Step1 = Voice File A

Step 2 = Voice File C

Step 3 = Voice File A

Step 4 = Voice File D

Step 5 = Voice File B

Step 6 = Voice File B

Step 7 = Voice File E

Total use 3 Group , 7 Steps

Voice duration= Hello + Good Morning + John + Tom + Mary

= 1.5'' + 3'' + 1'' + 1'' + 1.5''

= 8''

Total duration = 8'' (20''-8'' = 32'' space are free , can add more Voice File)

◆ SK020G Serial Mode Timing

TG1=Edge/Unhold/Retrigger

TG3=Reset PIN

● PWM

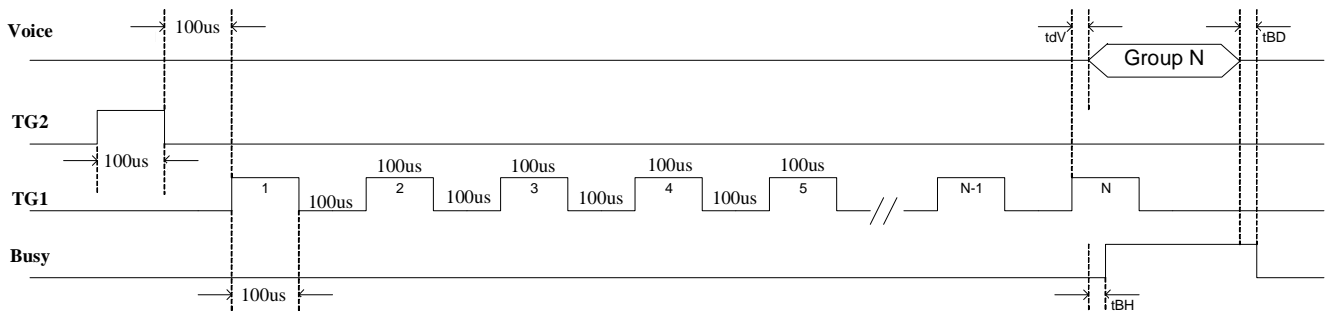

● DAC

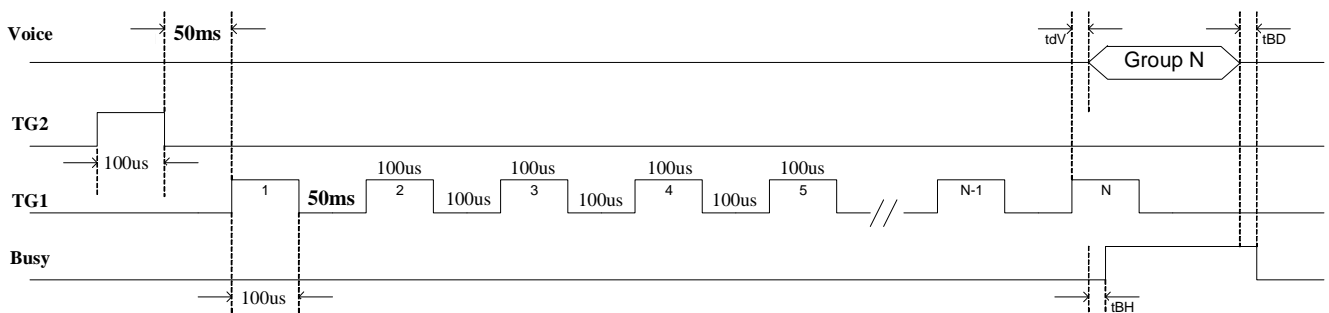

◆ SK020G CPU Mode Timing

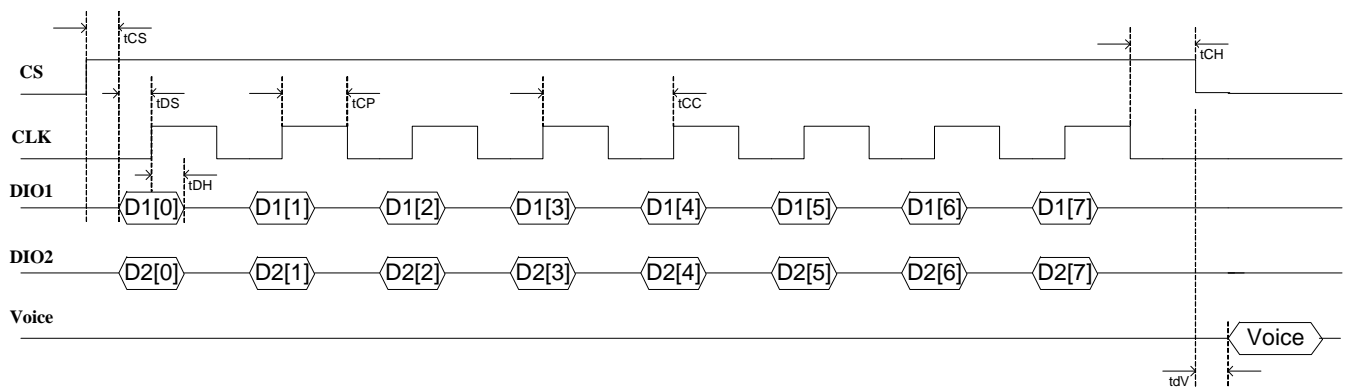

Command	PIN	HEX	[7]	[6]	[5]	[4]	[3]	[2]	[1]	[0]	Description
START	DIO1	A5h	1	0	1	0	0	1	0	1	Wake up the chip
	DIO2	05h	0	0	0	0	0	1	0	1	
END	DIO1	81h	1	0	0	0	0	0	0	1	Power down the chip into standby status
	DIO2	05h	0	0	0	0	0	1	0	1	
RESET	DIO1	83h	1	0	0	0	0	0	1	1	Stop the Playback and wait a new command
	DIO2	02h	0	0	0	0	0	0	1	1	
PAUSE	DIO1	83h	1	0	0	0	0	1	0	1	Pause the Playback and hold at the Voice data
	DIO2	07h	0	0	0	0	0	1	1	1	
RESUME	DIO1	05h	0	0	0	0	0	1	0	1	Resume Playback from the previous Voice data
	DIO2	07h	0	0	0	0	0	1	1	1	

Play Address Command is generated by the Tool.

◆ **SK020G Voice Wave & Output Status**

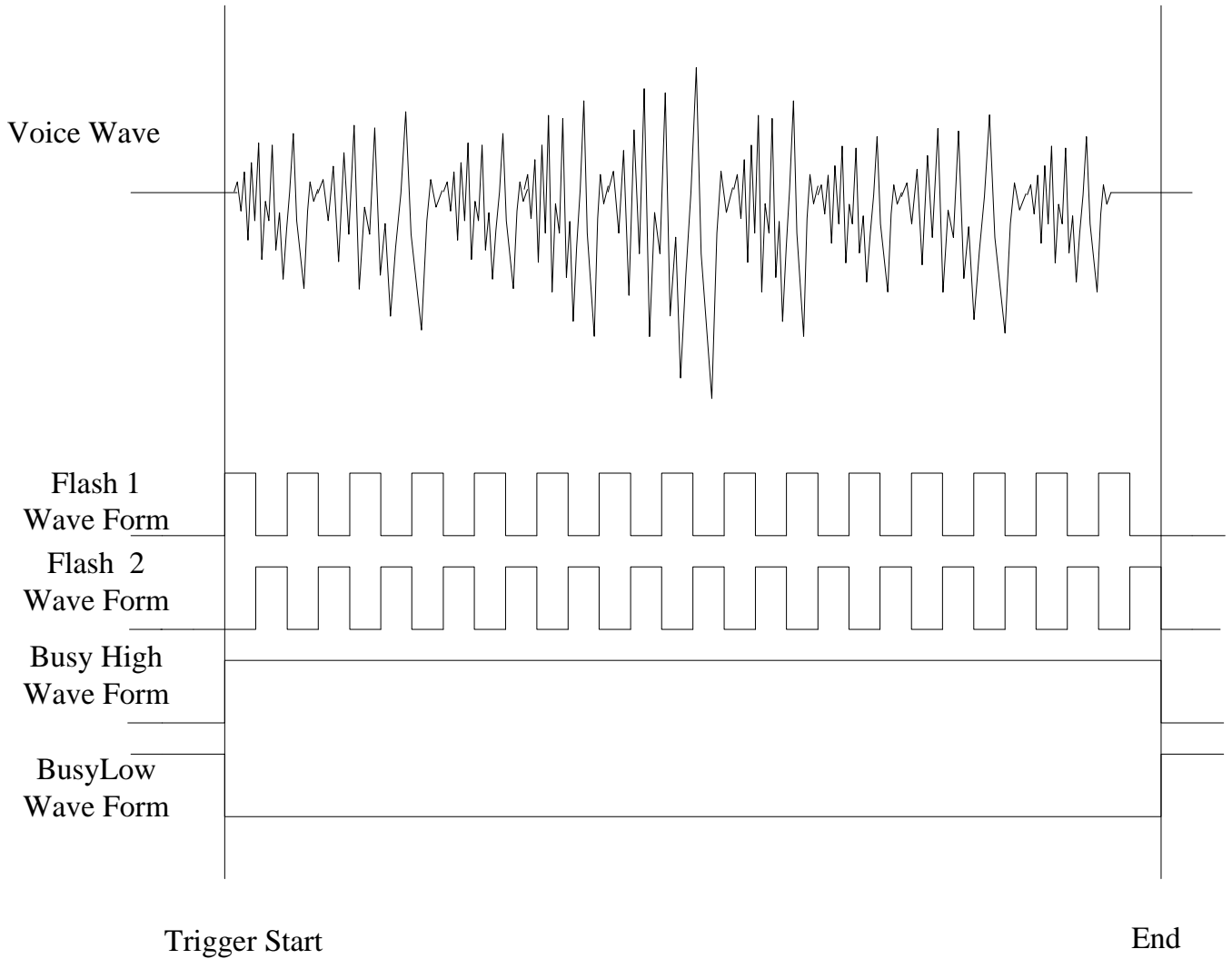

◆ DC Electrical Characteristics

Item	Symbol	Min	Typ	Max	Unit	Condition
Operating voltage	VDD	2.4	3.0	3.6	V	
Standby current	I _{sb}		1	5	uA	VDD=3V,no load
Operating current	I _{op}		600		uA	VDD=3V,no load
Drive current of Output	I _{od}		10		mA	VDD=3V VOUT=0.6V
Sink current of Output	I _{os}		30		mA	VDD=3V VOUT=2.4V
Drive current of PWM	I _{od}		200		mA	VDD=3V,VOUT=1.5V
Sink current of PWM	I _{os}		200		mA	VDD=3V,VOUT=1.5V

◆ AC Electrical Characteristics

Symbol	Characteristic	Rating			Unit
		Min.	Typ.	Max.	
tdb	Key Trigger debounce time (long)	14			ms
tdb	Key Trigger debounce time (short)	50			us
tBH	Busy signal output hold time	200			us
tBD	Busy signal output delay time	200			us
tdV	Voice output delay time	200			us
tCS	Chip Select setup time	1			us
tDS	Data In setup time	1			us
tDH	Data In hold time	1			us
tCP	Clock Pulse Width	1			us
tCC	Clock Cycle time	2			us
tCH	Chip Select hold time	1			us

◆ **SK020G Package Information**

SK020G-S08B

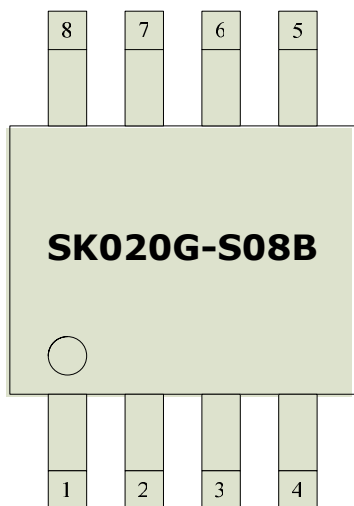

PIN	NAME
1	TG2/RSTB
2	TG1
3	TG3
4	TG4
5	VSS
6	PWM1
7	VDD
8	PWM2/DAC

SK020G-D08B

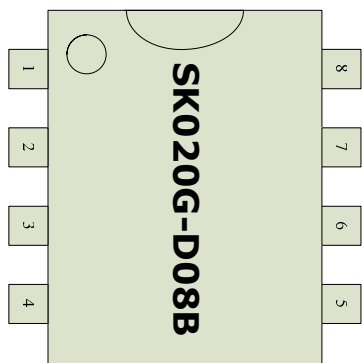

PIN	NAME
1	TG2/RSTB
2	TG1
3	TG3
4	TG4
5	VSS
6	PWM1
7	VDD
8	PWM2/DAC

◆ Writer Mapping Description

Writer Pin : **TG2,TG1,TG3,TG4,PWM1,VDD,VSS**

OTP Writer Power Board Pin Mapping Table				
DIP 20	DIP 48	PAD Name	TG005-SO8B	TG005-D08B
1 - VPP	37 - VPP	1-TG2/RSTB	1-TG2/RSTB	1-TG2/RSTB
2 - DIO1	38 - DIO1	3-TG3	3-TG3	3-TG3
3 - DIO2	39 - DIO2	4-TG4	4-TG4	4-TG4
4 - GND	11 - GND	5,6-VSS	5-VSS	5-VSS
5 - TEST	X	X	X	X
17 - RSTN	10 - RSTN	X	X	X
18 - CLK	12 - CLK	7-PWM1	6-PWM1	6-PWM1
19 - CS	13 - CS	2-TG1	2-TG1	2-TG1
20 - VCC	14 - VCC	8-VDD	7-VDD	7-VDD

◆ Writer Board Slot Location (DIP20)

